



# NEXRAD Radar Operations Center

## ZDR Calibration

for the  
NEXRAD Technical Advisory Committee  
8-9 March 2011

by  
Darcy Saxion

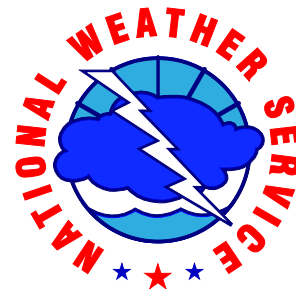



# Overview

- Goal
  - Provide a technical overview, show the progress towards improvement, and share the current status of ZDR calibration
- Overview:
  - Historical Information
  - Basics
  - Brief Calibration Overview
  - Past Progress
  - Outstanding Issue
  - Mitigation Strategies



# Historical Information



# Historical Information

- QPE requires a 0.1 dB accuracy in ZDR values (Sachidananda and Zrnić, 1985)
- Vertical pointing has been the 'gold standard' for fine tuning ZDR calibration to meet the 0.1 dB accuracy requirement
- Since the WSR-88D cannot vertically point, L-3/Baron adopted a microwave metrology method
  - Summary of this method was presented to the TAC November 2009 (Ice)



# Basics



## Radar System

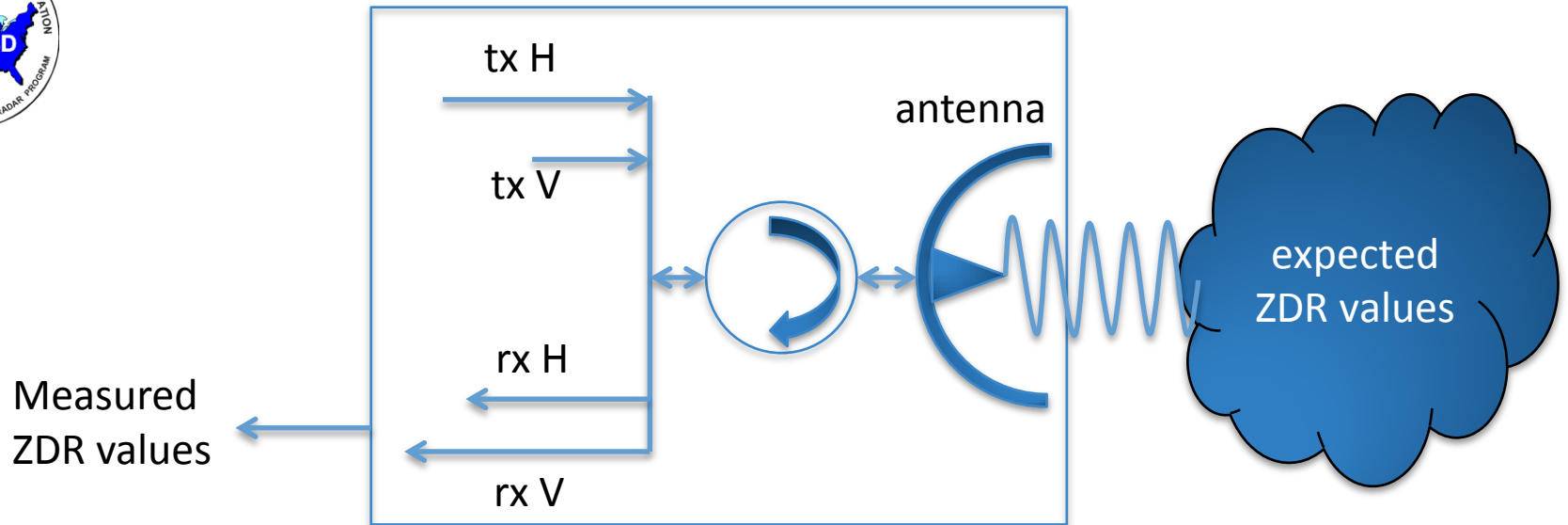

We can only 'see' what the radar measures.

We know what ZDR values we expect to see.\*

\* Since we don't really know what the true ZDR values are, we make well educated guesses about what we expect to see in 'known' precipitation types.



## Radar System

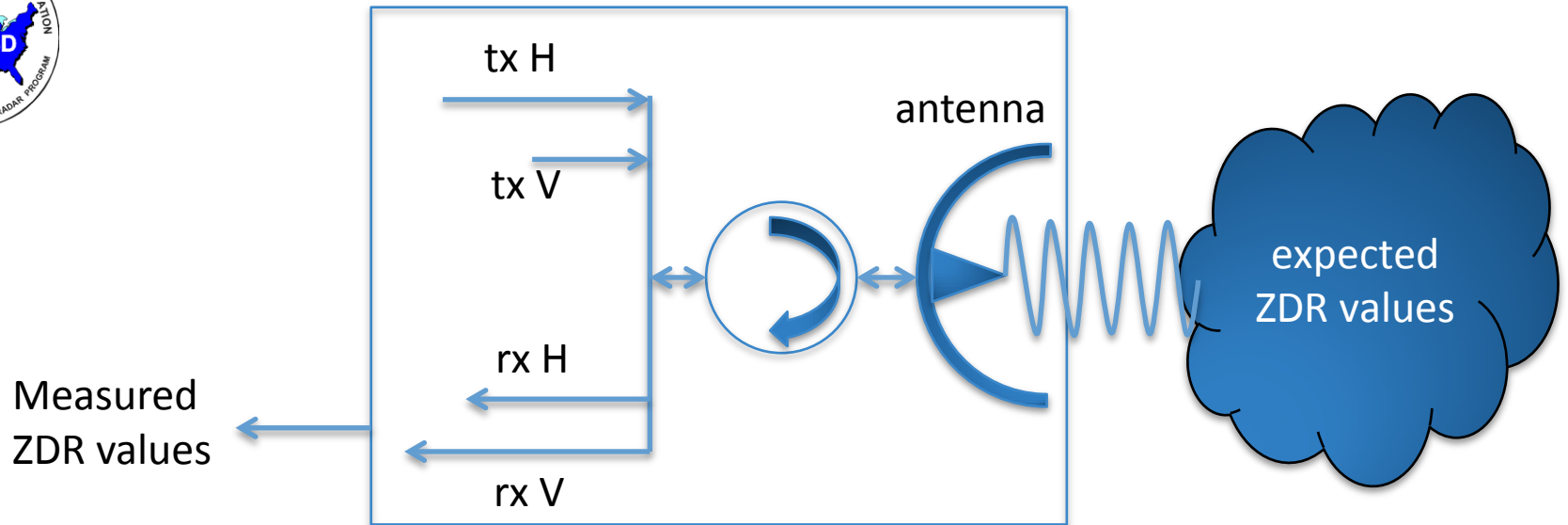

- In general, Differential Reflectivity (ZDR) is the ratio of H power to V power
  - If  $H=V$ , then ZDR is 1 (and  $10 \cdot \log_{10}(1) = 0$  dB, units of ZDR)
- There can be a ZDR introduced by the system
  - Referred to as System Differential Reflectivity ( $ZDR_{sys}$ )
  - In this diagram, different transmit (tx) and receive (rx) line lengths are directly proportional to different amounts of loss
- Differential reflectivity of the *system* affects all measured ZDR values
  - Thus, we try to account for and remove it from the measured ZDR values



## Radar System

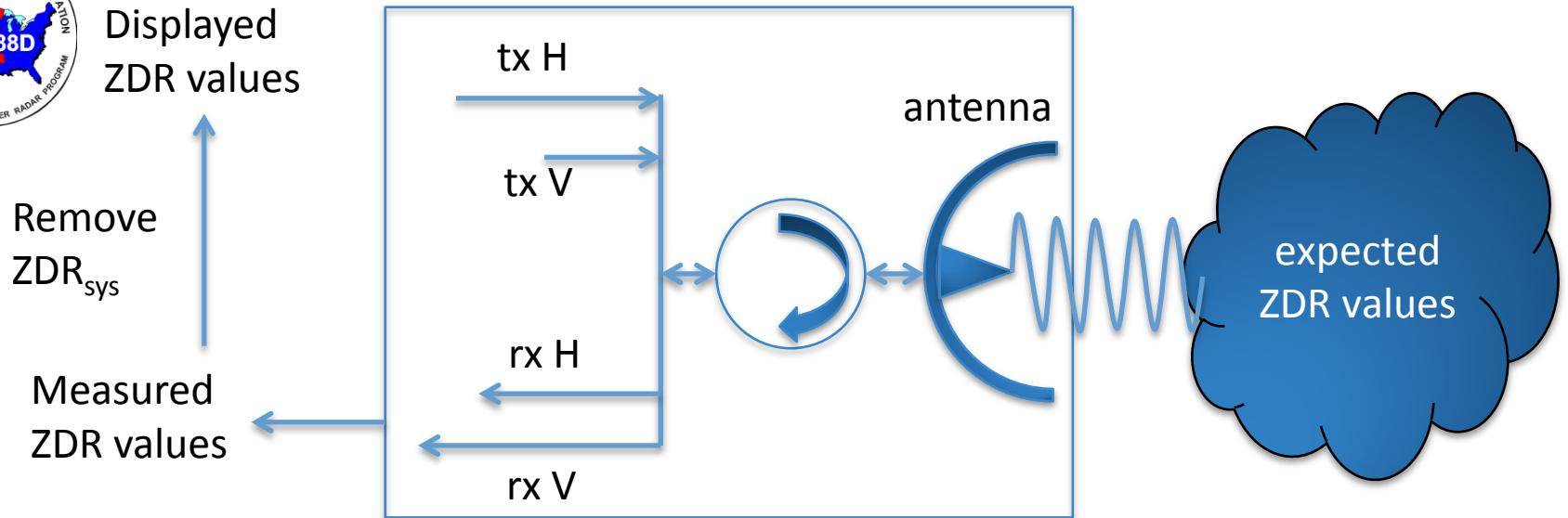

Displayed ZDR values (ZDR) are intended to match expected ZDR ( $ZDR_{exp}$ )

$$ZDR_{exp} \cong ZDR = ZDR_{measured} - ZDR_{sys}$$

Where:

- **System differential reflectivity ( $ZDR_{sys}$ )** – differential reflectivity introduced by the system
- **ZDR** – differential reflectivity displayed by the system
- **Expected ZDR ( $ZDR_{exp}$ )** – expected ZDR values for known precipitation types
- **ZDR error** – difference in expected ZDR values ( $ZDR_{exp}$ ) and ZDR values





## Radar System

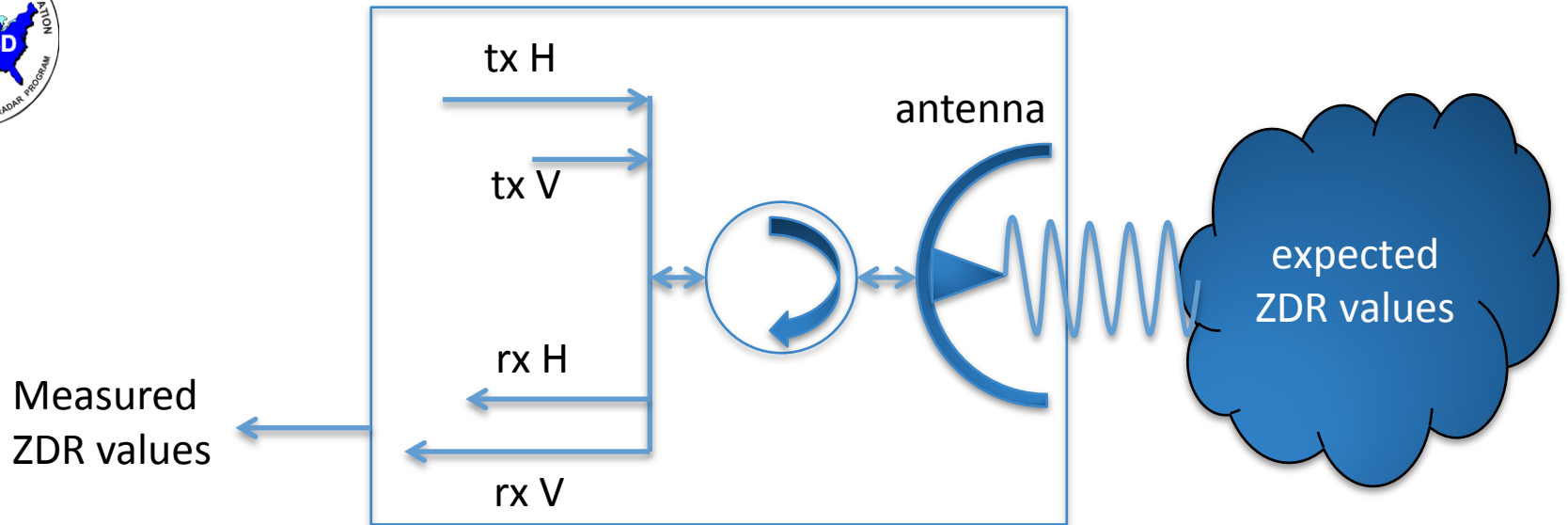

- A 'snapshot' of system differential reflectivity is measured during the offline ZDR calibration
- It is then maintained during online system performance checks and VCP retrace

$$\text{ZDR}_{\text{sys}} = \text{Initial ZDR}_{\text{sys}} + \text{compensation for instrument drift}$$

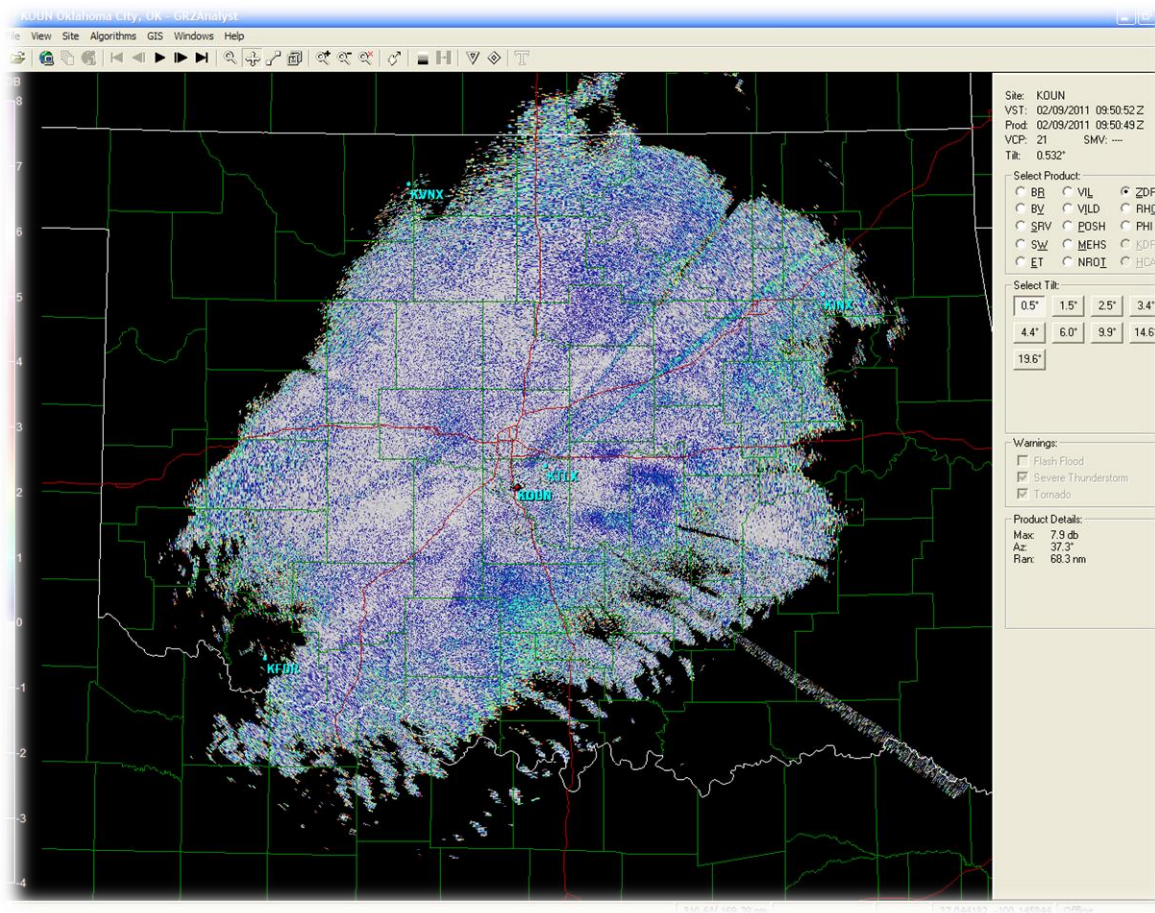

Since

$$ZDR = ZDR_{\text{measured}} - ZDR_{\text{sys}}$$

Then

- If  $ZDR_{\text{sys}}$  is correct, then the ZDR values match expected ZDR
- If  $ZDR_{\text{sys}}$  is incorrect, then the ZDR values have an error
  - If  $ZDR_{\text{sys}}$  is incorrect from drift correction, then ZDR values have a varying error from performance check to performance check
  - If  $ZDR_{\text{sys}}$  is incorrect from calibration, then ZDR values have a constant error



# Brief Calibration Overview



# Calibration Overview

- Calibration Equation:

$$\text{ZDR}_{\text{sys}} = (2 * \text{ZDR}_{\text{ant}}) + \text{ZDR}_{\text{tx}} + \text{ZDR}_{\text{rx}}$$

- $\text{ZDR}_{\text{ant}}$  from snapshot
- $\text{ZDR}_{\text{tx}}$  from snapshot and monitored in performance checks (usually every 8 hours)
- $\text{ZDR}_{\text{rx}}$  from snapshot and monitored on retrace (every VCP)

# Dual Polarization Channel Calibration Paths

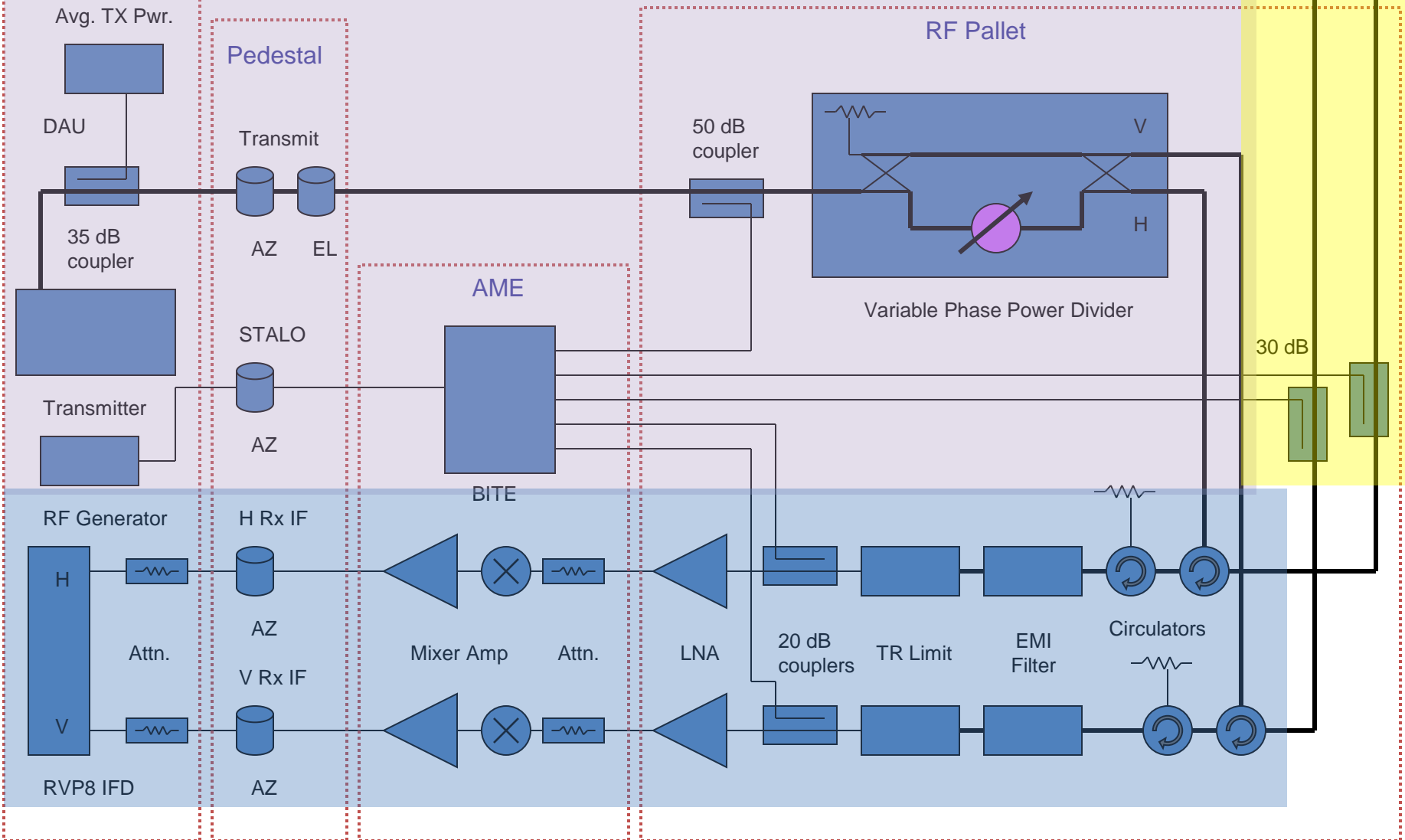



# Past Progress



H Pwr in Kw    V Pwr in kW    ZDR (Sys)

KOUN Oct 30 00:04Z through Nov 1 12:41Z 2010

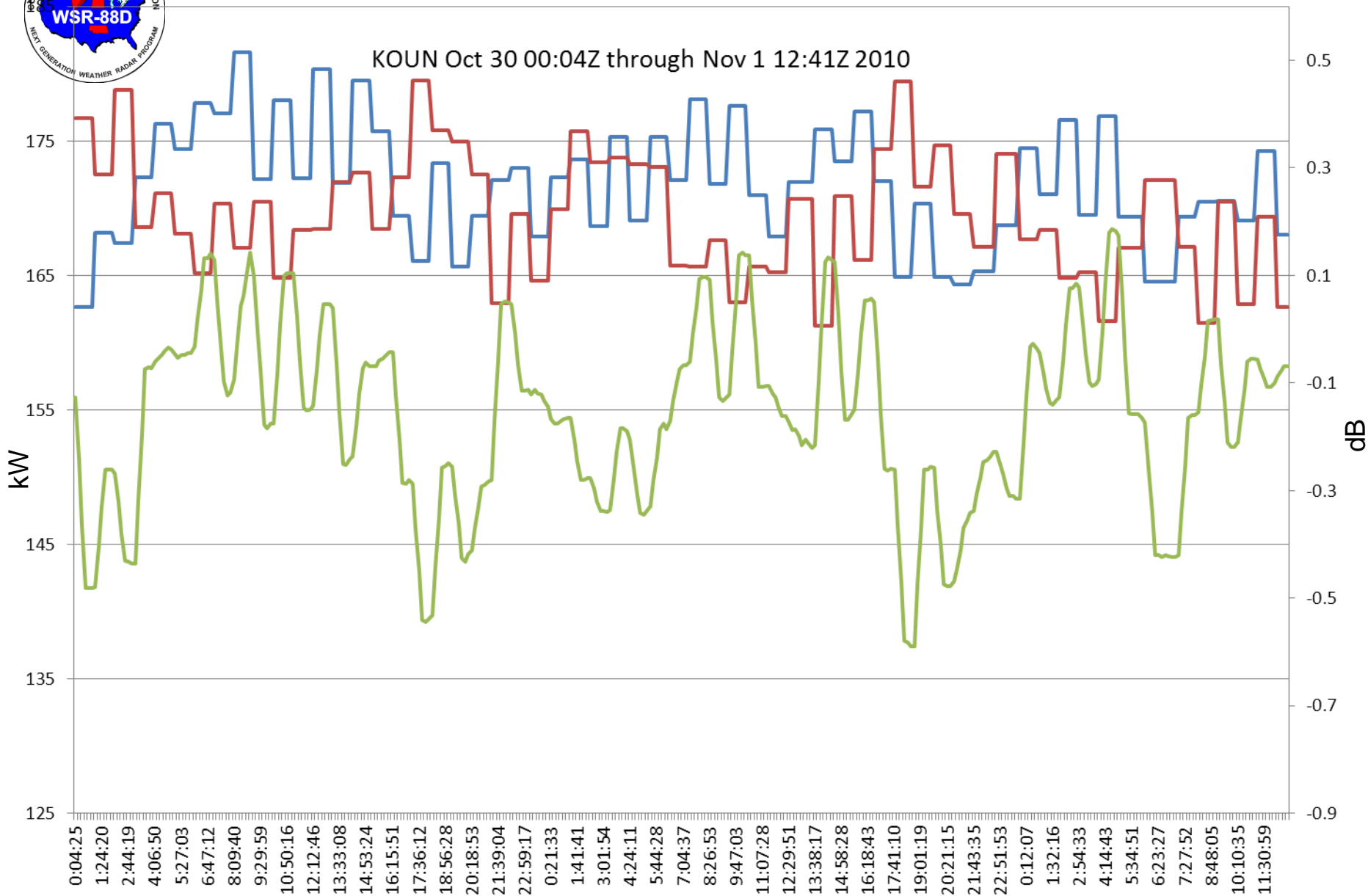



# Past Progress

- Initial investigations by L-3/Baron, Nov 2010
  - Replaced RF Pallet, receiver module, and waveguide pressurization dehumidifier
    - No improvement seen
      - Still useful
        - Verified that no variations in power exist due to splitting
  - Many cables replaced
    - Connectors worn due to excessive use
- Key Issues identified and corrected by L-3/Baron Nov 2010
  - GFE delay line
    - Moved to the AME for the dual pol upgrade
    - New location caused variations in losses due to temperature changes caused by Peltier blowing hot air on it
    - Correction includes moving and shielding it in the AME
  - Bad KDTX cable
    - In the calibration path
    - Performance check measurements were not stable





# Past Progress

- Additional improvements by L-3/Baron, Dec 2010 – Jan 2011
  - Heliax cables replaced coaxial cables for all critical ZDR calibration paths
  - QN adapters (non-torque connector) on 8 critical connection paths (i.e., AME, 30 dB coupler, TR Limiter)
  - Brackets to stabilize LNAs
  - Delay line relocated to the bottom of the AME
  - Locking compound on all 'permanent' RF connections
  - Torque specifications defined for all RF connections
  - System stability test software added
  - Modified ladder bar to minimize number of moves during calibration procedure



# Past Progress

- ***Good improvement! Variations in H/V power splitting are smaller and more stable***
- Variations in ZDR bias are within requirements
  - Expected less than 0.1 dB change from VCP to VCP to meet accuracy requirements



— H Pwr in Kw — V Pwr in kW — ZDR (Sys)

### KOUN Oct 30 00:04Z through Nov 1 12:41Z 2010

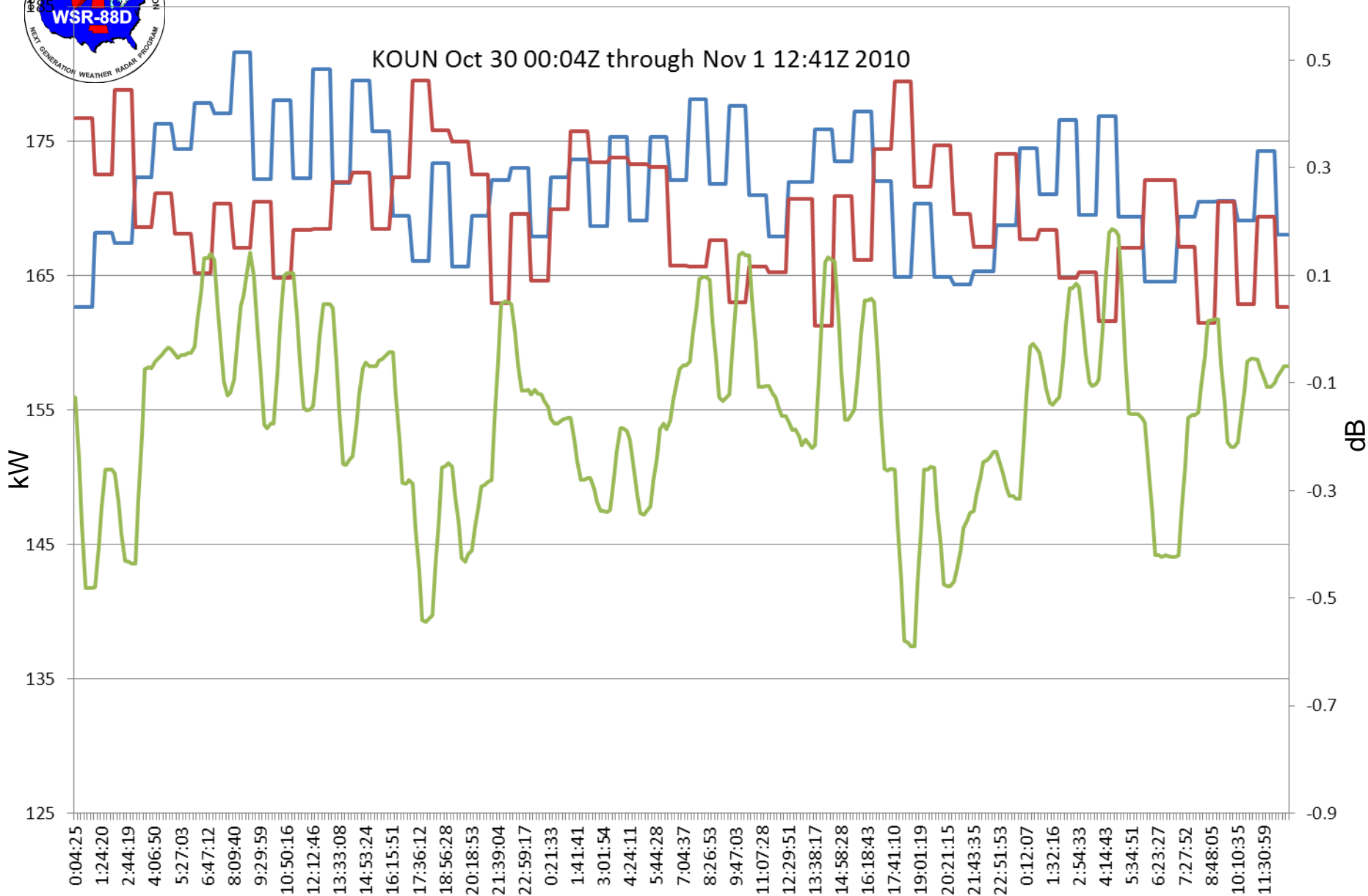



— H Pwr in kW — V Pwr in kW — ZDR (Sys)

### KOUN Feb 1 00:07Z through Feb 2 22:25Z 2011

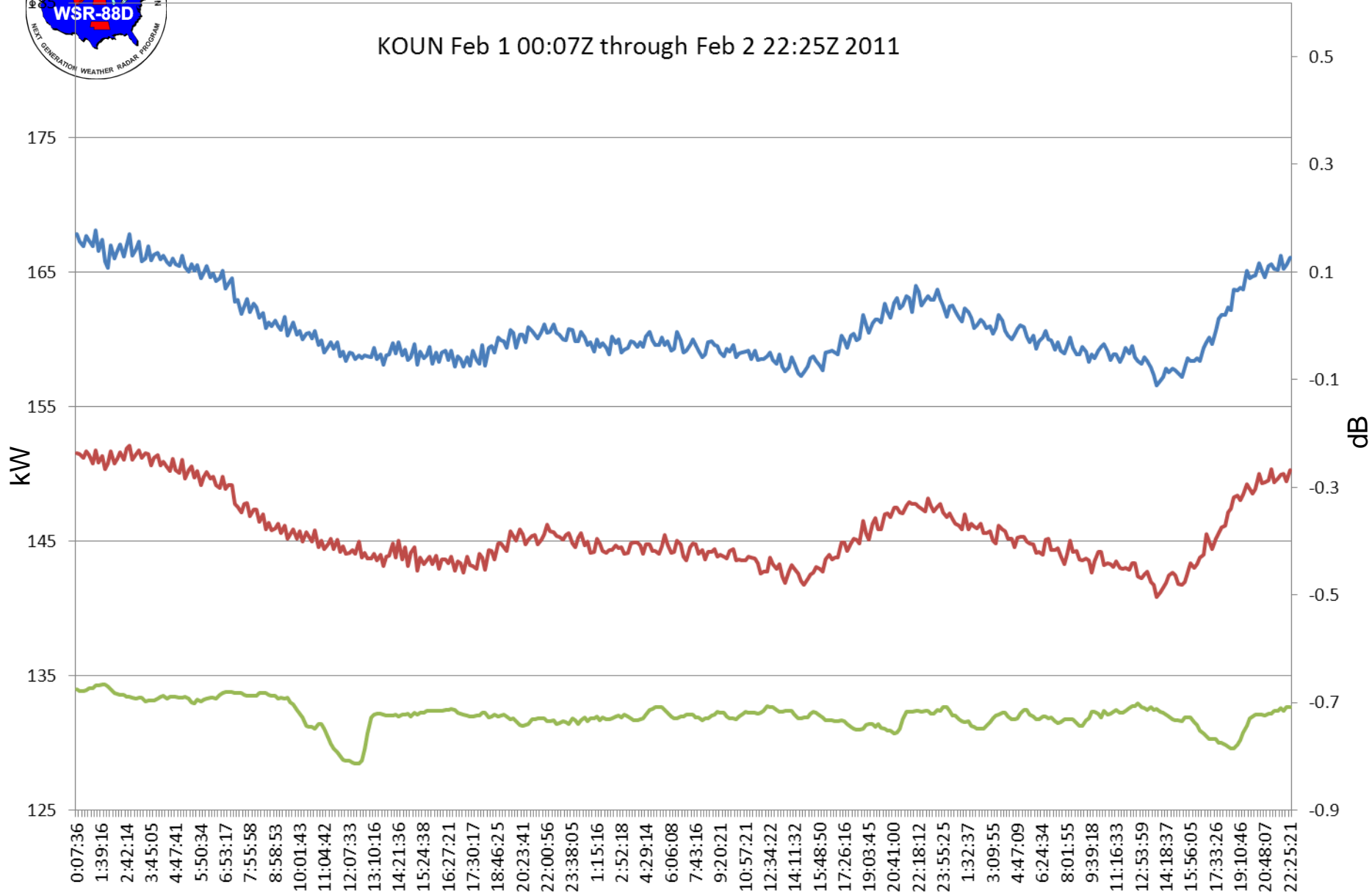



# Outstanding Issue



## Radar System

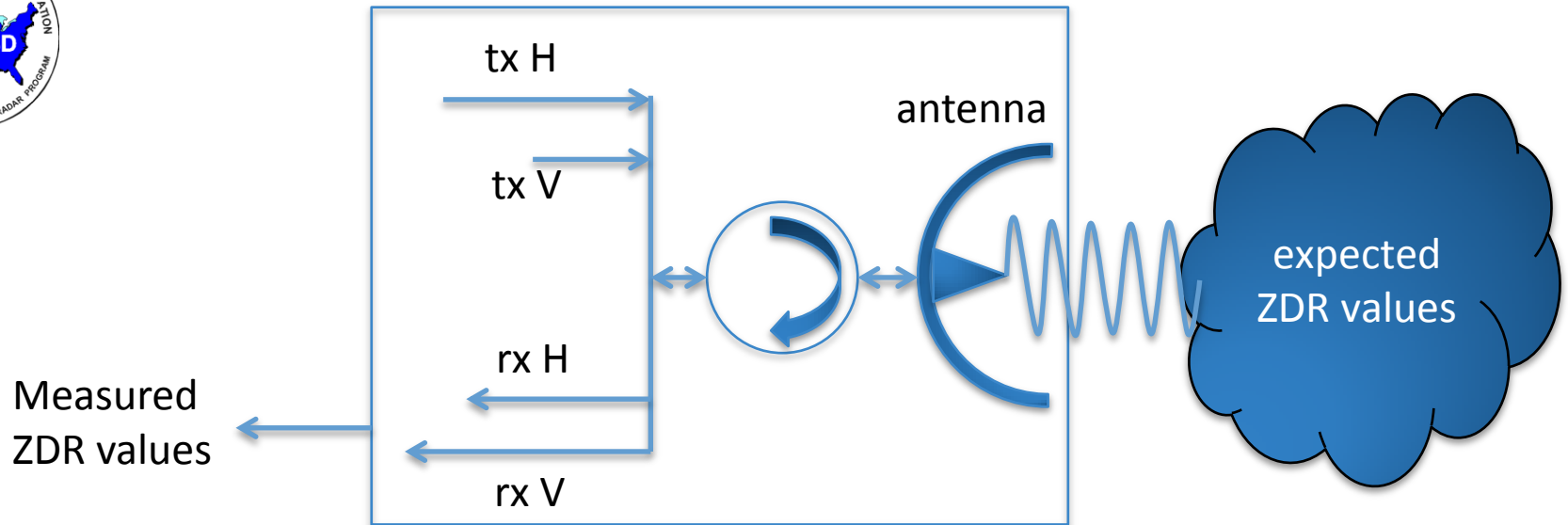

$$\text{ZDR}_{\text{sys}} = \text{Initial ZDR}_{\text{sys}} + \text{compensation from instrument drift}$$

- Compensation due to instrument drift has been shown to be stable
- Remaining issue to be solved is:
  - Initial  $\text{ZDR}_{\text{sys}}$  from calibration appears to be too low by  $\sim 0.5$  dB
  - L-3/Baron continue to investigate

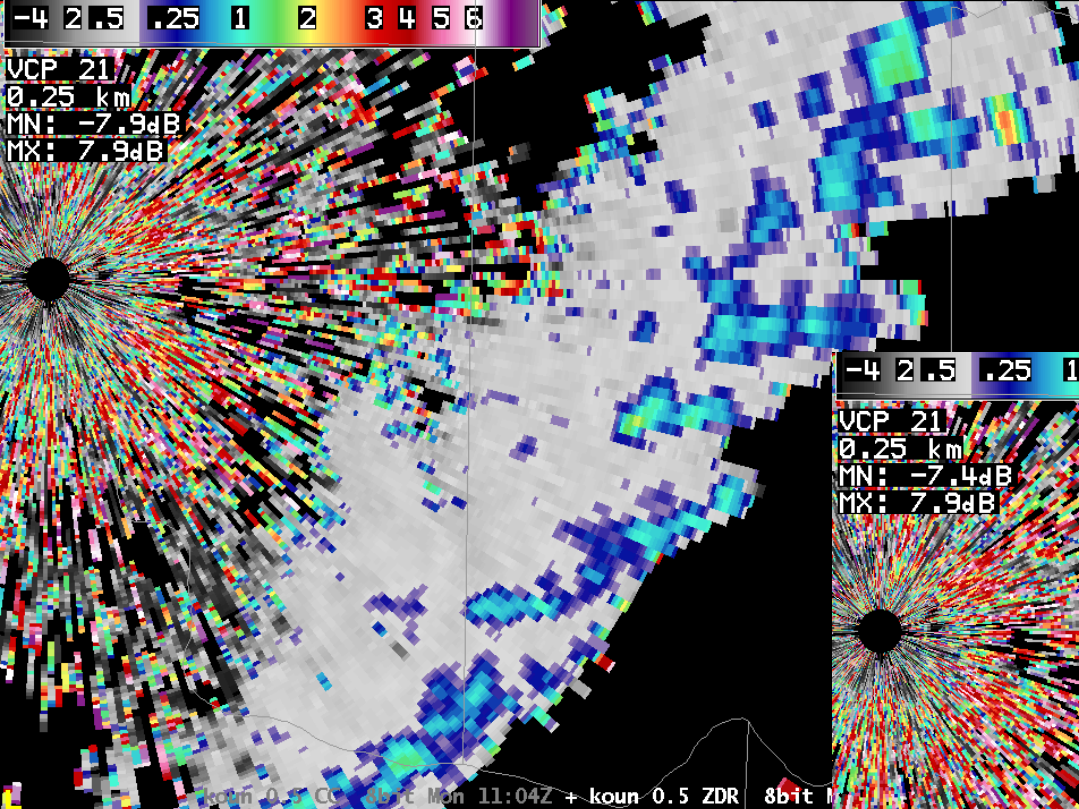

ZDR data collected on 29 November 2011

Same ZDR data corrected by 0.5 dB

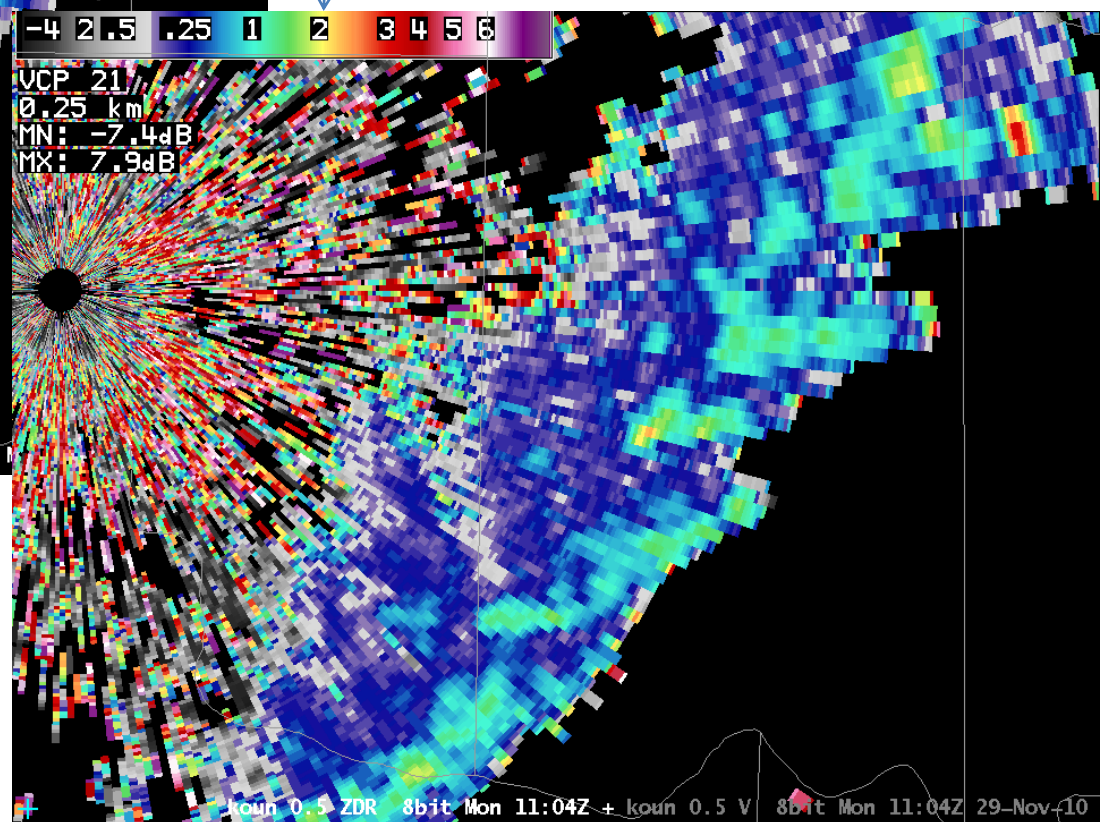

Outstanding issue:

ZDR values are consistently low by approximately 0.5 dB.



# Mitigation Strategies





# Mitigation Strategies

- System Stability Test will help with ZDR calibration validation
  - KVN<sub>X</sub> (Vance AFB) was recently upgraded to dual pol
  - Allows for continuous operation
    - Shares coverage with nearby radars
    - Can compare with KOUN
  - Comparing KVN<sub>X</sub> ZDR calibration results with KOUN ZDR calibration will provide insights
    - If KVN<sub>X</sub> is off by 0.5 dB, then probably a process issue
    - If KVN<sub>X</sub> is off by a different amount, then possibly an inherent lack of accuracy in microwave metrology which may not meet requirements



# Mitigation Strategies

- Crosspolar Power Technique
  - The ROC needed a method to validate ZDR calibration
    - The DQ MOU, with funding from OST, supported development of the crosspolar power technique by NCAR
  - NCAR showed that this technique provides equivalent results as vertical pointing in 2006 on their S-Pol radar (briefed to the TAC, Spring 2007, Hubbert)
    - They were able to compare three calibration methods
      - Microwave metrology
      - Vertical pointing
      - Crosspolar power technique
  - This may provide a method to fine tune ZDR calibration



# Mitigation Strategies

- Crosspolar Power Technique – implementation status
  - NCAR is modifying their software to calculate system differential reflectivity ( $ZDR_{sys}$ ) from sun-scan and ground clutter scan data from KOUN
  - The ROC is refining the data collection process
    - During this effort, we discovered that the variable phase power divider (VPPD) did not provide adequate isolation when transmitting from only one channel
    - L-3/Baron have supported refinements in the VPPD for better isolation
    - The upgraded VPPD will be installed on KVNIX
  - Testing will continue to validate the technique on the L-3/Baron dual pol design



# Mitigation Strategies

- Other solutions considered
  - OHD methodology to dynamically correct for ZDR values & use corrections in DP QPE algorithm
    - Methodology has not been formally tested
    - Relies on the Hydrometeor Classification Algorithm (HCA) which is not designed for colder weather events
  - Train forecasters to make manual ZDR adjustments via adaptable parameters at the RPG



# Summary

- The L-3/Baron microwave metrology approach provides stable, but not proven accurate, system differential reflectivity
- The ROC is implementing the crosspolar power technique developed by NCAR to validate ZDR calibration
- Two other methods exist to adjust ZDR calibration by determined ZDR error



# Thank you



# Questions?



# Backup Slides

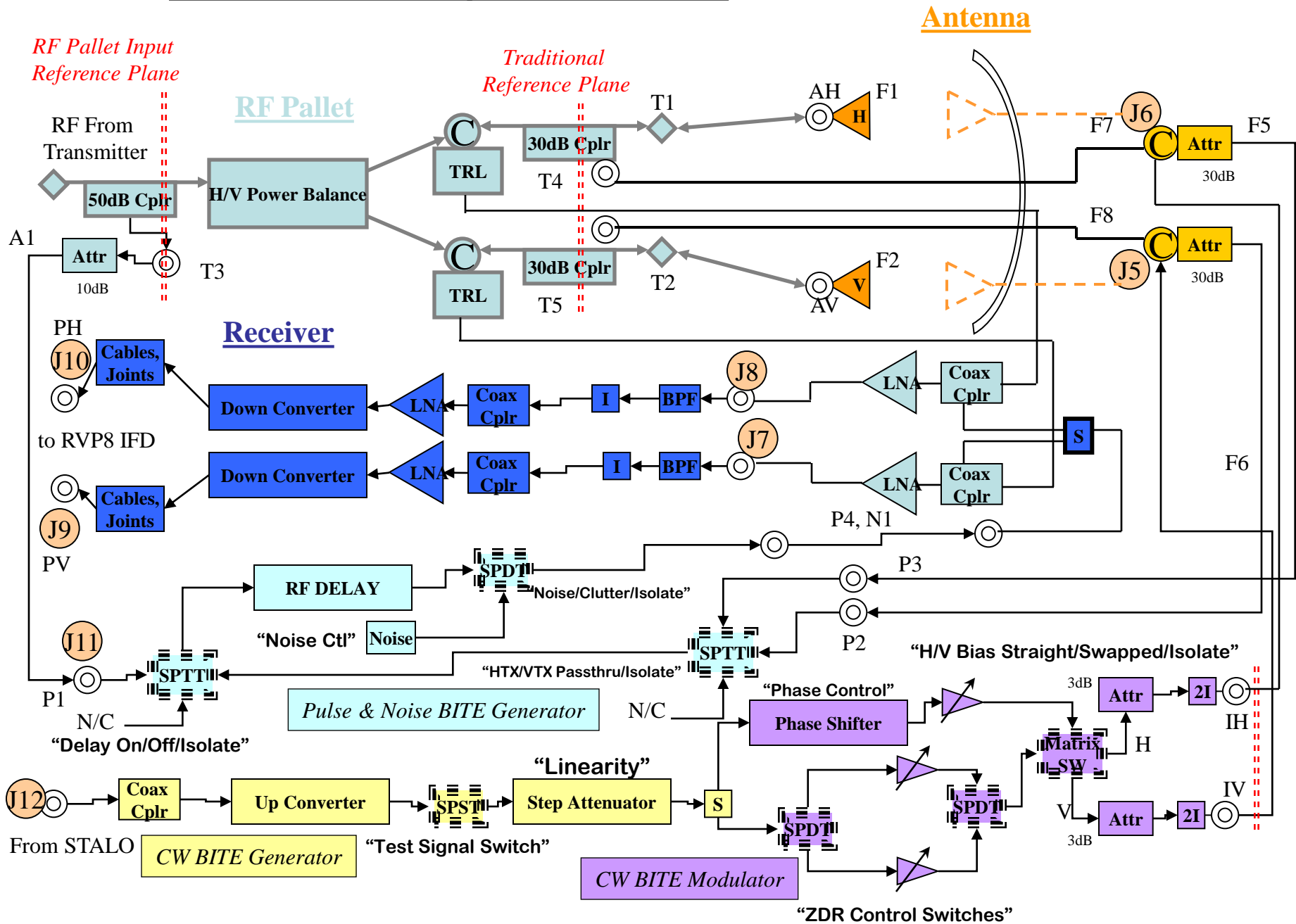





# Simplified ZDR Process Flow Diagram

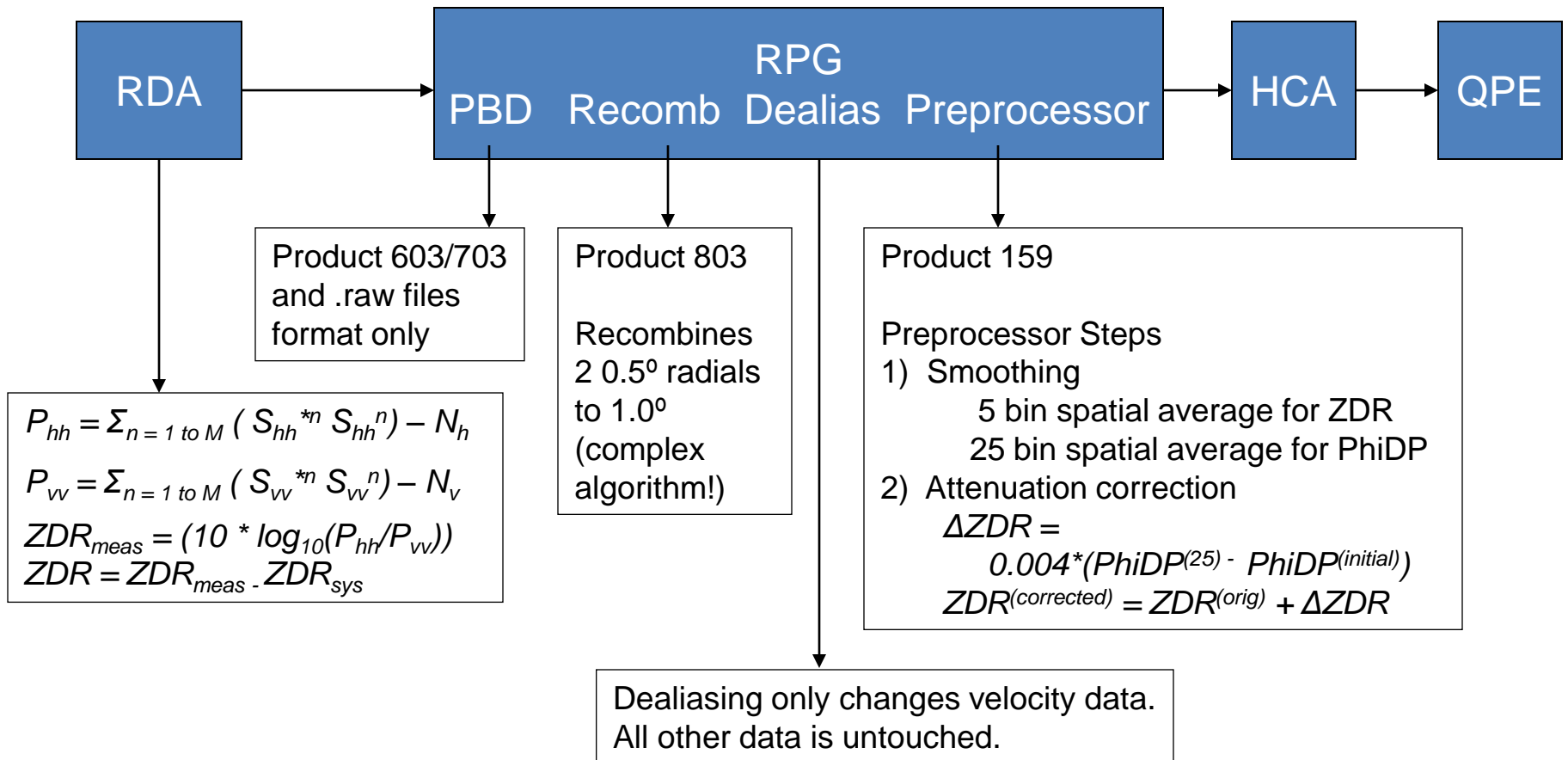



# Crosspolar Power Technique

Differential Reflectivity ( $ZDR_{meas}$ ):

Reflectivity for the H channel ( $Z_H$ ) equals the transmit power (T), times the gains in the transmit path ( $G_{TH}$ ), times the gains in the receive path ( $G_{RH}$ ), times the power received from the backscatterer ( $S_{HH}$ ) :

Similarly,  $Z_V$  for the V channel equals the transmit power (T), times the gains in the transmit path ( $G_{TV}$ ), times the gains in the receive path ( $G_{RV}$ ), times the power received from the backscatterer ( $S_{VV}$ ) :

ZDR is the ratio of the  $Z_H$  and  $Z_V$ , so our *measured* ZDR values are:

$$\frac{G_{TH} G_{RH} S_{HH}}{G_{TV} G_{RV} S_{VV}}$$

Canceling common terms yields (assumes transmit power ratio does not change):

$$\frac{S_{HH}}{S_{VV}} \cdot \frac{G_{RH}}{G_{RV}}$$

The highlighted part is ZDR introduced by the system ( $ZDR_{sys}$ ). We want to account for and remove this!



# Crosspolar Power Technique

Now, look at crosspolar power data. First, observe transmit on V channel, receive on H channel:

Next observe crosspolar power data with transmit on H channel, receive on V channel :

Take the ratio of the crosspolar powers  $R_{XV}$  and  $R_{XH}$  to find the differential crosspolar power:

\_\_\_\_\_

Assuming that the transmit power ratio does not change and radar reciprocity gives  $P_{HV} = P_{VH}$ , then canceling common terms yields :

\_\_\_\_\_



# Crosspolar Power Technique

Collect sun scan data for the H and V channels for information regarding the receive path:

The power is equal for both the H and V channel from the sun. Take the ratio and cancel like terms:

— —



# Crosspolar Power Technique

Combining  $ZDR_{meas}$ , crosspolar power ratio, and sun bias for H/V,

$$ZDR_{meas} \left( \frac{P_{cross}}{P_{ZDR}} \right) \left( \frac{1}{\cos^2 \theta} \right) = ZDR_{sys}$$

Essentially, the sun scan information about the received path allows us to compare measured ZDR and measured crosspolar power by removing the repeated receiver information from measured ZDR and crosspolar power. It can be thought of as a conversion factor.:

$$ZDR_{meas} \left( \frac{P_{cross}}{P_{ZDR}} \right) \left( \frac{1}{\cos^2 \theta} \right) = ZDR_{sys}$$

From the crosspolar power technique, the measured ZDR is corrected by:

$$ZDR_{meas} \left( \frac{P_{cross}}{P_{ZDR}} \right) \left( \frac{1}{\cos^2 \theta} \right) = ZDR_{sys}$$

Therefore C should equal  $ZDR_{sys}$  from the calibration process,